

# Impedance Matching

By Chris Prioli, AD2CS

When transferring energy from one circuit (or device) to another circuit (or device), maximum energy transfer will occur when the impedance of the circuits or devices is matched. There are several ways to accomplish this match, most notably the resistive match and the transformer match. In amateur radio, such impedance matching is important so as to limit voltage standing wave ratio or VSWR, and thereby reduce or limit power reflection from the target circuit back to the source circuit.

Impedance matching can impose losses in the circuit as a by-product of the matching process. These are often unavoidable, but they can be kept to a minimum with careful planning and design. We will begin our discussion with resistive matching networks.

Suppose we are faced with matching a 75Ω output to a 50Ω input, and we decide to do this using a resistive L-pad matching network. The L-pad, in this case, consists of a series input resistor and a shunt output resistor.

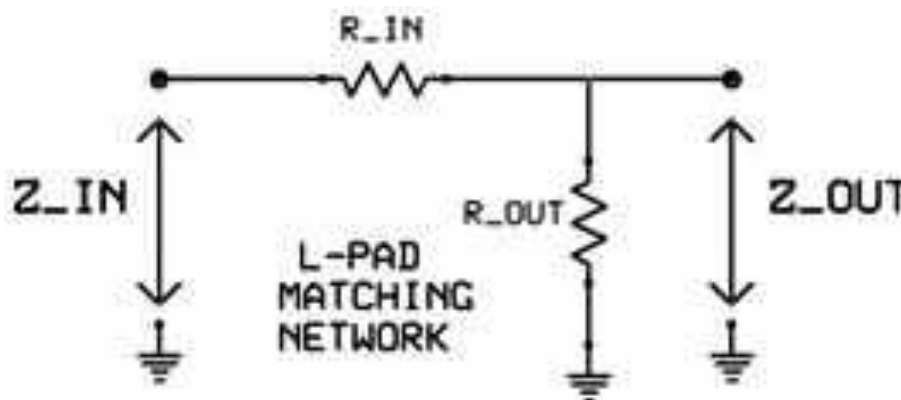

What values of resistors would be needed? The resistor values can be calculated arithmetically using the following formulas :

$$Z_{IN} = R_{OUT} (R_{IN} + Z_{OUT}) / R_{OUT} + (R_{IN} + Z_{OUT}); \text{ and}$$
$$Z_{OUT} = R_{IN} (R_{OUT} = Z_{OUT}) / R_{IN} + (R_{OUT} + Z_{IN})$$

These work out to the following formulas :

$$R_{IN} = Z_{IN} \times \alpha \text{ and } R_{OUT} = Z_{OUT} / \alpha \quad \dots \text{where } \alpha = \sqrt{1 - (Z_{OUT} / Z_{IN})}$$

So... let's put some actual values into place and see what happens. We were given earlier that the source circuit output impedance, which becomes the input impedance for our matching network, is 75Ω. We were also told that the input impedance of our target circuit, which becomes the output impedance of our matching network, is 50Ω.

This will give us the following :

$$R_{IN} = Z_{IN} \times \alpha$$

or

$$R_{IN} = 75 \times \alpha$$

or

$$R_{IN} = 75 \times \sqrt{1 - (50/75)}$$

or

$$R_{IN} = 75 \times \sqrt{1 - (0.6667)}$$

or

$$R_{IN} = 75 \times \sqrt{0.3333}$$

or

$$R_{IN} = 75 \times 0.57732$$

or

$$R_{IN} = 43.299\Omega$$

*Impedance Matching - Continued on page 2*

This tells us that the series input resistor should be a 43Ω resistor. Now let's do the same thing to calculate the value of the shunt resistor. This is done using the following formula :

$$\begin{aligned}
 R_{OUT} &= Z_{OUT} / \alpha && \text{or} \\
 &\text{or} && R_{IN} = 50 / \sqrt{(0.3333)} \\
 R_{OUT} &= 50 / \alpha && \text{or} \\
 &\text{or} && R_{IN} = 50 / 0.57732 \\
 R_{OUT} &= 50 / \sqrt{(1-(50/75))} && \text{or} \\
 &\text{or} && R_{IN} = 86.607\Omega \\
 R_{IN} &= 50 / \sqrt{(1-(0.6667))}
 \end{aligned}$$

Now we know that the shunt resistor must have a value of 86Ω for this matching network to do the job as desired. Thus, if we go back to our original diagram, we get the following :

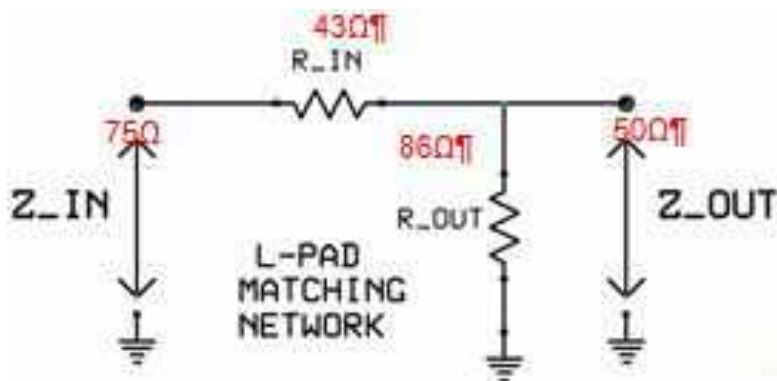

This process will work for any pair of impedance values. Simply plug in the necessary input and output impedance values and work the arithmetic to derive the series and shunt resistor values. Remember that when working at RF, non-inductive resistors are to be used so as not to introduce excessive parasitic inductance into the match. Also remember that the resistive network must be rated for the anticipated power levels that will be passed through the network.

Another common method of impedance matching is through the use of a transformer as the matching device. This is accomplished by manipulating the (design) turns ratio to achieve the match that is needed. The governing equation is expressed as :

$$Z_S / Z_P = (N_S / N_P)^2$$

where  $Z_S$  is the secondary impedance,  $Z_P$  is the primary impedance,  $N_S$  is the turns count of the secondary winding, and  $N_P$  is the turns count of the primary winding.

Suppose we have that old combination again, 75Ω and 50Ω, except that now we are needing to match a 75Ω input impedance of one stage to the 50Ω output impedance of the previous stage. In every case, the impedance ratio is equal to the turns ratio squared. Remember that a ratio can be expressed in the format  $x:y$  or in the format  $x/y$ . In this case, if we use the  $x/y$  format and input the numbers, we will get the following :

$$Z_S / Z_P = (N_S / N_P)^2 \text{ or } 75 / 50 = (N_S / N_P)^2 \text{ or } 1.5 = (N_S / N_P)^2$$

$$\text{or, arithmetically rearranged, } \sqrt{1.5} = N_S / N_P \text{ or } \sqrt{1.5} = 1.22$$

Thus, the turns ratio is 1:1.22 while the impedance ratio is 1:1.5. Starting somewhere, we need to decide upon a number of turns for one of the windings in order to determine the number of turns for the opposite winding. These turns values must, as shown by the equations above, have a 1:1.22 ratio between them. Suppose we started with 9 turns for the primary (50Ω) side of the transformer. What would that give us for the secondary (75Ω) winding? That can be calculated by multiplying 9 by 1.22, which would then give us 11 turns. Thus, an impedance matching transformer for the 50Ω to 75Ω pairing might be one having 9 turns on its primary winding and 11 turns on its secondary winding. This would also work with, say, 4.5 turns primary and 5.5 turns secondary, or 18 turns primary and 22 turns secondary. So long as the ratio is maintained, the impedance match will be valid. Diagrammatically, that circuit would look something like the diagram at right.

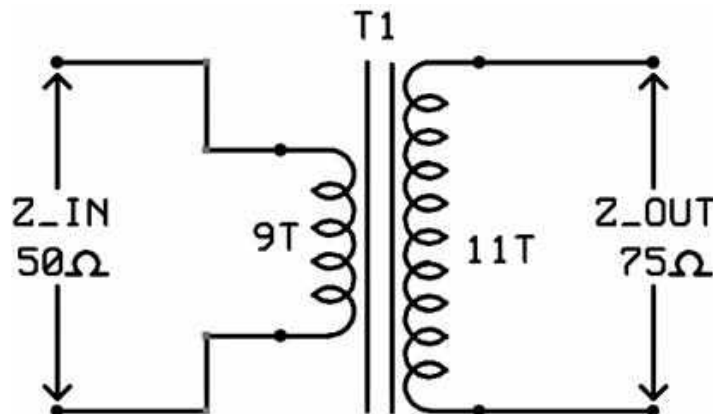

Note that the actual turns counts may be widely divergent from those shown, but that the turns ratio must remain the same for the impedance values given.

Transformer impedance matching is quite common and fairly simple to implement. The major drawback is that the transformer, depending upon its physical form factor and location, may cause inductive responses in other nearby components. Some methods of reducing that effect are to shield the transformer, or to position it away from and/or at right angles to potential inductive target components, or to utilize a toroidal core for the transformer. Again, the transformer must be capable of handling the power levels that will be passed through it. This will largely be a function of the diameter of the wire used in winding the coils.

A useful aspect of the matching transformer is that can also serve as a feedline type matching device. For example, an unbalanced coaxial input feedline to a matching transformer may be taken out as a balanced open wire line output feedline, and vice-versa. In amateur radio, these devices are called baluns, for their ability to match an unbalanced grounded 50Ω coaxial feedline to a balanced floating or ungrounded 450Ω feedline.

Shown on **Page 4** is a homebrew implementation of a **transformer matching circuit (Figure 1)**, the work of British ham **M0UKD**. Note that the whole unit is self-contained in a weather-tight enclosure. This design makes use of a fairly large air gap “bread slicer” type of variable capacitor as well as what appears to be a homemade transformer wound on an air core. The accompanying schematic diagram gives us some insight into the transformer. The note indicates that while the turns ratio is 1:8, the impedance ratio is what we would expect... 1:64. **M0UKD** goes on to tell us that the secondary winding has an inductance of 1.5μH while the variable capacitor ranges between 15pF and 350pF. This impedance match device is intended to match the 50Ω output impedance of a modern radio to the 3200Ω input impedance of his half-wave end-fed dipole antenna. Looking carefully at the enclosure, one can just make out the counterpoise/coax ground toggle switch at the top to the left of the capacitor and next to the PL-259 connector. The ground terminal is located at the bottom of the enclosure. **M0UKD** has gone so far as to place a label containing the unit schematic on the inside of the enclosure cover for future reference. This is a well-implemented design in every visible way.



Figure 1 : M0UKD's Homebrew Transformer Matching Circuit

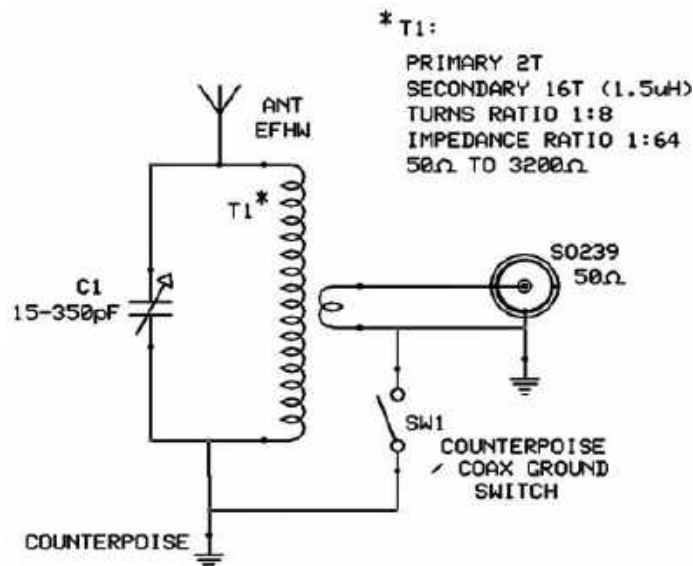

What would be the effective operational frequency range of this unit? That range can easily be calculated by using the data shown in the schematic to run a couple of quick equations. The basic equation that would apply here is  $f = 2\pi LC$  where  $f$  is the frequency of interest in Hertz,  $L$  is the circuit inductance in Henrys, and  $C$  is the circuit capacitance in Farads.

The calculation for the high end of the range (lowest capacitance value) is as follows :

$$f = 1 / (2\pi \times \sqrt{LC})$$

$$f = 1 / 6.2832 \times \sqrt{(15 \times 10^{-12}) \times (1.5 \times 10^{-6})}$$

$$f = 1 / 6.2832 \times \sqrt{(0.000000000015) \times (0.0000015)}$$

$$f = 1 / 6.2832 \times \sqrt{(0.000000000000000225)}$$

$$f = 1 / 6.2832 \times (4.7434 \times 10^{-9})$$

$$f = 1 / 0.00000002980373088$$

$$f = 33,352,846.2535 \text{ Hz}$$

$$f = 33.352846 \text{ MHz}$$

The calculation for the lower end of the range, or that using the highest capacitance value, is as follows :

$$f = 1 / (2\pi \times \sqrt{LC})$$

$$f = 1 / 6.2832 \times \sqrt{(350 \times 10^{-12}) \times (1.5 \times 10^{-6})}$$

$$f = 1 / 6.2832 \times \sqrt{(15 \times 10^{-12}) \times (1.5 \times 10^{-6})}$$

$$f = 1 / 6.2832 \times \sqrt{(0.000000000035) \times (0.0000015)}$$

$$f = 1 / 6.2832 \times \sqrt{(0.000000000000000525)}$$

$$f = 1 / 6.2832 \times (2.29128 \times 10^{-8})$$

$$f = 1 / 0.0000001439657$$

$$f = 6,946,098.9666 \text{ Hz}$$

$$f = 6.946099 \text{ MHz}$$

Thus, this homebrewed transformer matching device will match the 50Ω impedance of the radio to the 3200Ω impedance of the end-fed half-wave dipole antenna for the frequency range from about 7 MHz to about 33 MHz - a good portion of the ham operating spectrum.

Impedance matching can also be accomplished via some other circuits. A good example of this is the so-called LC match. This matching circuit consists of various combinations of inductors and capacitors, and are typically one of four basic topographies :

- **The Series-L network**
- **The Pi network**
- **The Shunt-L network**
- **The T network**

Each of these basic LC matching topographies is illustrated below :

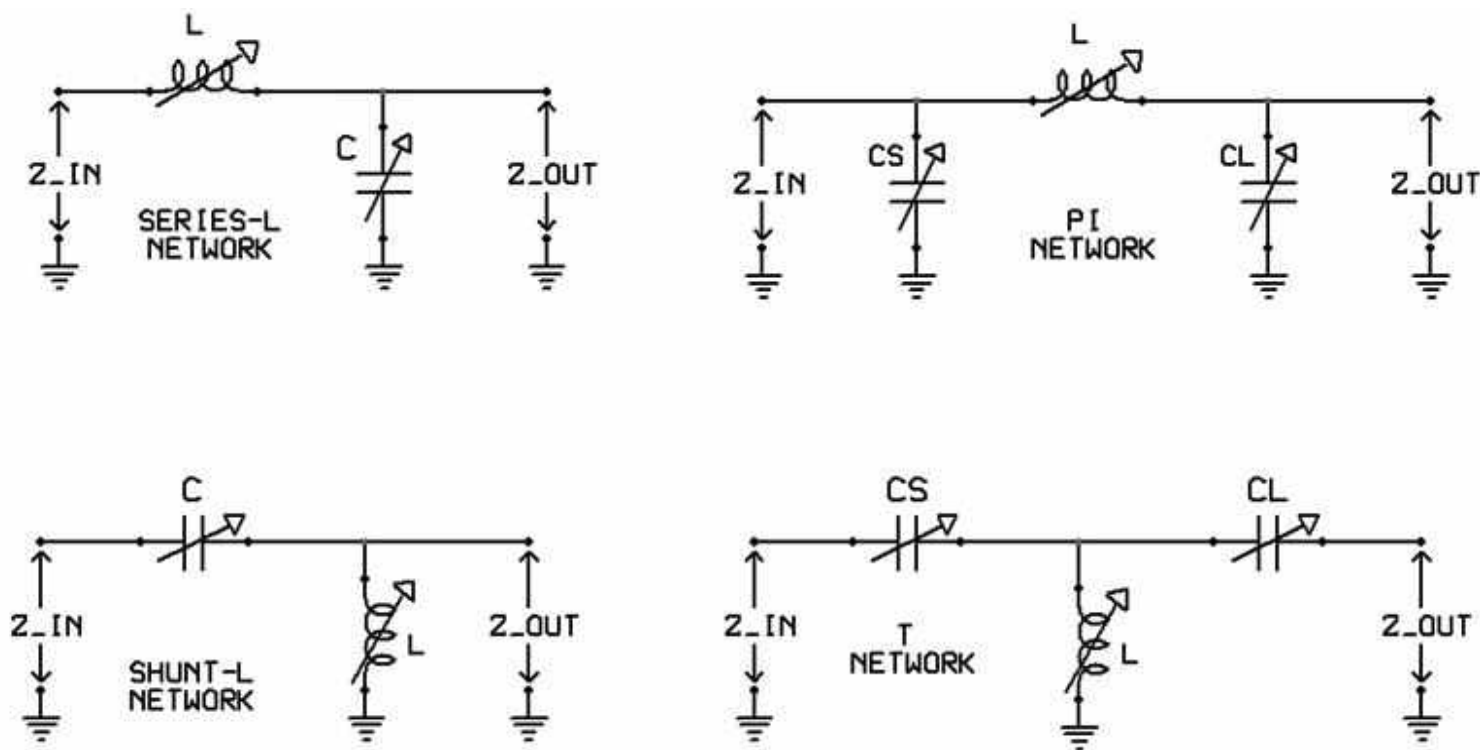

In these diagrams, all of the capacitive and inductive components are shown as being variable devices. In an actual working circuit, this may or may not be the case. Manufacturers may choose to install fixed components at some, or even most, of the component locations as a means of reducing construction costs. The use of variable capacitors and/or inductors vastly improves the capability to adjust the capacitance and inductance of the circuit, thereby gaining better control over the net circuit reactance. Improved reactance control yields more precise tuning and therefore better frequency control in both the transmit and receive modes of operation, though the transmit mode is where it is most important.

The naming conventions for these matching networks derive from the component arrangement or the layouts of the circuits. In the Series-L and Shunt-L, the “series” and “shunt” in the name refers to the position of the inductor, either in series with the matching network input, or across the output (or load) to ground. The “pi” arrangement refers to the positioning of the inductor in series with the input, between two shunt capacitors, forming a shape similar to the Greek letter *pi*. In a similar manner, the “T” topology is so named because of its unmistakable resemblance to the letter “T”. with the shunt inductor placed between the two series capacitors.

If it seems that these matching networks bear striking resemblances to certain filter circuits of which you may already be aware, it is because these circuits are in fact filter circuits at heart. As a general rule, a filter that uses a shunt inductance will often be a high-pass type of filter, while those that use shunt capacitances are most likely low-pass filters. Think of the shunt element as being a path to ground for certain frequencies contained in the signal imposed on the circuit. We know that capacitive reactance goes down as frequency goes up, meaning that the shunt capacitor will readily direct (or shunt) the higher frequencies to ground while the series inductor passes the lower frequencies through the circuit and on to the output. Similarly, with a shunt inductor, and the fact that inductive reactance goes down as the frequency goes down, the lower frequencies in the input signal are directed or shunted to ground, while the higher frequencies are allowed, by the series capacitor, to pass through the circuit to its output.

Another method used to achieve impedance matching is to use a stub of transmission line as the matching device. Described as  $\lambda/4$  matching ( $\lambda$ , the Greek letter **Lambda**, is the symbol used to represent wavelength), this method uses a segment of transmission line that is 1/4-wavelength long at the frequency of interest. The key is that the characteristic impedance ( $Z_0$ ) of the transmission line segment must be equivalent to  $\sqrt{(Z_{IN} \times Z_L)}$ . This is typically expressed as the equation  $Z_0 = \sqrt{(Z_{IN} \times Z_L)}$ . Let's take a look at how this would work if the antenna feed point impedance is 100 $\Omega$  and the coaxial cable impedance is 50 $\Omega$  :

$$\begin{aligned}Z_0 &= \sqrt{(Z_{IN} \times Z_L)} \\Z_0 &= \sqrt{(50 \times 100)} \\Z_0 &= \sqrt{(5000)} \\Z_0 &= 70.71\end{aligned}$$

The closest standard cable characteristic impedance available for use in this case would be 75 $\Omega$  cable, which is what would then be used. A segment of 75 $\Omega$  cable should be cut to the length that would equate to one-quarter of a wavelength at the desired transmission frequency and inserted between the existing feedline and the antenna terminals.

The bottom line is that although there are several means by which we can achieve an impedance match, the method chosen depends upon the circuit at hand and the needs of the circuit designer. Choose the method that best suits your needs and circumstances.