

RCA WO-33A Three-Inch Oscilloscope Rejuvenation

By Chris Prioli, AD2CS

Not too long ago, I picked up a well-used three-inch oscilloscope, an **RCA WO-33A unit (Figure 1)**, with the expressed intention of converting this 'scope into another piece of test equipment, namely a graphic semiconductor curve tracer. The main working parts of the 'scope would remain untouched, but an additional small power supply and a circuit board would be added in to provide the new functions that I wanted. The oscilloscope had its rubber bezel, but it did not have a graticule. This did not make any difference, because the graticule is not specifically needed for the curve tracer to operate acceptably. Down the road, I may make a new graticule out of some colored acetate sheeting onto which I can imprint a grid and scale, but that is another project.



Figure 1 : RCA WO-33A Oscilloscope (with graticule)

The 'scope had been, as already mentioned, very well used, and its overall condition reflected that fact. The non-polarized two-wire power cord was in bad shape, with cracks and splits in several points along its length. The faceplate had been splattered with light blue paint droplets, and the vertical input BNC jack on the front panel was bent and badly corroded, making it unusable as an input jack.

All of these were minor issues in the overall scheme of things. Far more important to me was the electrical condition of the unit. I removed the 'scope from its cabinet and I hooked it up to what I call my "safety trinity" (Figure 2) - my dim bulb current limiter, my Variac™, and my isolation transformer to see what it would do. When I powered it on, the dim bulb went to full brightness and just stayed there, never dimming as it should have done if the 'scope were intact electrically. This indicated either a direct short circuit from line to neutral, or else some severe capacitor leakage.



Figure 2 : Safety Trinity

I powered it down and took some resistance readings from the power cord blades to each other and to chassis. The ohmmeter showed an open circuit between either of the power cord blades and the chassis, and it showed a resistance on the order of 12 megohms between one blade and the chassis (with the power switch turned "ON"), and about 7 megohms between the other blade and the chassis. This indicated that there was no direct short circuit, so the problem was most likely capacitor leakage.

A quick look at the 'scope showed that in all likelihood, all but one of the capacitors installed were factory devices. The WO-33A was introduced to the trade in 1959 as a portable on-site oscilloscope, meant to be carried to the customer's home for on-the-spot repairs of TV sets and radios. It was produced into the early 1970's, as is evidenced by the earlier copies having RCA's classic circular logo while the later editions carry the newer stylized three-letter logo used in that era. The 'scope was offered in both kit and pre-wired form and sold for about \$80 for the kit form or \$130 for the factory-built version. Of course, those 1959 costs would look like \$840 and \$1360, respectively, today.

AD2CS RCA WO-33A Scope Rejuvenation - Continued on page 2

Anyway, the capacitors that I believe were all factory components were all of a type - ceramic tubes with wax filling, all marked as being CERACAP devices (**Figure 3**) from American Radionic Company, Incorporated. Some research showed that American Radionic is still around today, located now in Palm Coast, Florida, some sixty miles south of Jacksonville, where they relocated after leaving Danbury, Connecticut in the late 1980's. Their AmRad line of motor-run capacitors are considered to be world-class products. However, in the 1950's and 1960's, they were a major supplier of wax and paper capacitors to consumer TV and radio manufacturers.



Figure 3 : CERACAP Examples

The only capacitor that was not an American Radionics CERACAP was C40, a 5µF 1kV capacitor in the plate circuit of the 6C4 high-voltage rectifier tube. This capacitor had very faint and therefore unreadable markings that showed up once I removed the electrician's tape with which the capacitor had been wrapped. The capacitor itself is of an all-metal exterior construction, and was most likely wrapped to keep it from shorting the components over which it laid when placed in circuit in the 'scope.

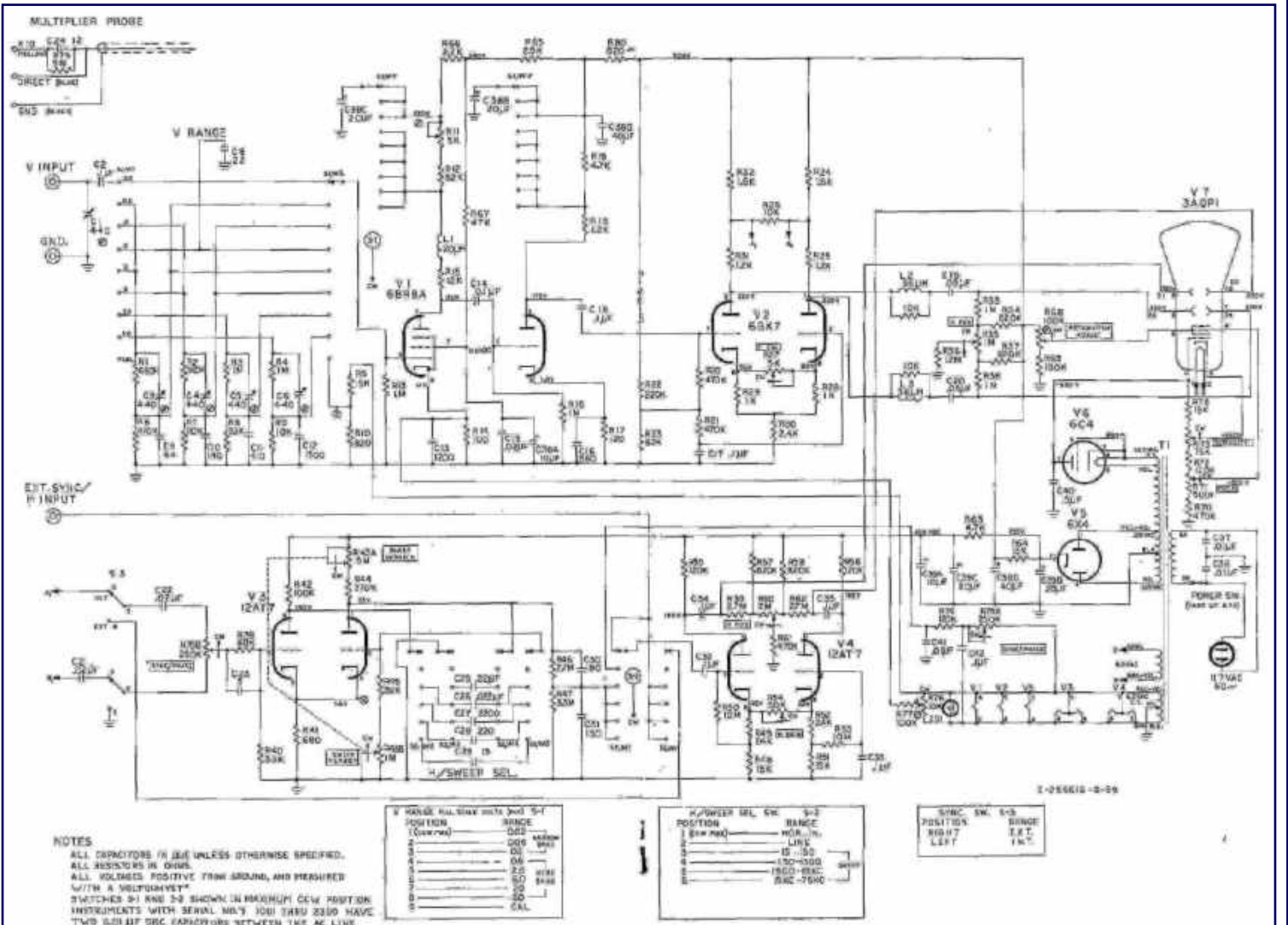

Figure 4 : WO-33A Schematic Diagram

Consulting the **schematic (Figure 4)** and the parts list in the assembly manual which was readily available online, I made a list of all of the capacitors used in the oscilloscope, and then I ordered in those which I did not have in stock. With the exception of that 5 μ F 1kV capacitor, I opted to use the **Vishay MKT1813-series (Figure 5)** of axial metallized polyester film capacitors throughout the unit, and I matched the type with a CDE/Illinois Capacitor MWR-series axial metallized polyester film device for the oddball capacitor in the bunch.

Before installing any of the replacement film capacitors, I used my **outside foil indicating device (Figure 6)** to identify the outside foil lead of each capacitor. This allowed me to orient each capacitor in the same direction as the original with respect to the outside foil lead. The orientation of the capacitor in this regard may be an important point if the equipment designer relied upon the shielding effect of the outside foil of the capacitors as a part of the overall circuit shielding scheme, whether it be for avoiding the pickup of stray RF in the device or for any other purpose. In the assembly manual for the WO-33A oscilloscope, care is taken to instruct the builder as to which end of each capacitor, as regards the outside foil indicator band, gets connected to which point in the circuit. This makes it obvious that the designer did indeed use the shielding effect of the outside foils of capacitors as a design point in this unit.

In every case, the replacement capacitors were a fraction of the size of the original capacitors being replaced. I went through the unit methodically, replacing each and every CERACAP capacitor with a new film capacitor. There were two voltage ratings used among the original capacitors, 200V and 400V, with the exception, of course, of the one high-voltage device. The replacements were 250V and 400V types. In all cases except for the high-voltage capacitor, the original values were available and thus were installed. The 5 μ F high-voltage capacitor was replaced by a 4.7 μ F 1kV device. In all cases where spaghetti tubing had been used on the original capacitors, it was re-installed on the lead(s) of the replacement devices.

After replacement of the capacitors, I decided to investigate the exact condition of the capacitors that I had removed. I did this using a capacitor tester of my own design and build (**Figure 7**), which tests capacitors for leakage and for ESR. What I found, detailed in **Table 1**, is quite revealing.



Figure 5 : MKT1813 0.1 μ F 400VDC Capacitor

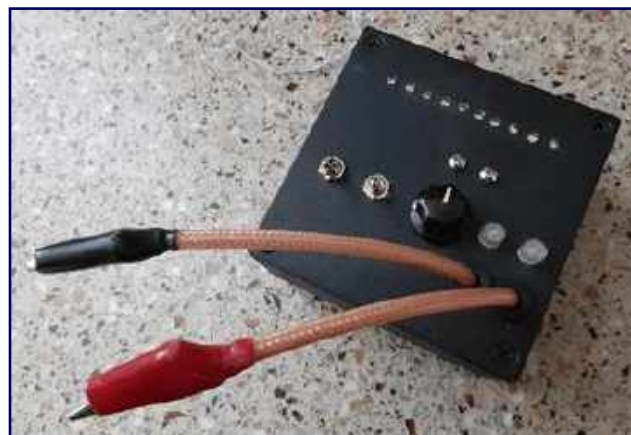

Figure 6 : Capacitor Outside Foil Indicator Device



Figure 7 : Capacitor Leakage & ESR Tester

Table 1

Device ID	Value	Test Voltage	Leakage Current	ESR
C2	0.1 μ F / 400VDC	400VDC	260 μ A	5 Ω
C14	0.1 μ F / 400VDC ¹	400 VDC	105 μ A	4.4 Ω
C17	0.1 μ F / 400VDC	400VDC	220 μ A	5 Ω
C18	0.1 μ F / 400VDC	155VDC ³	500 μ A ³	4.6 Ω
C20	0.05 μ F / 200VDC	200VDC	350 μ A	8.9 Ω
C25	0.22 μ F / 400VDC	400VDC	120 μ A	3 Ω
C26	0.022 μ F / 400VDC	300VDC ³	500 μ A ³	10 Ω
C32	0.1 μ F / 400VDC	105VDC ³	500 μ A ³	4.8 Ω
C33	0.1 μ F / 200VDC	200VDC	75 μ A	6 Ω
C34	0.1 μ F / 200VDC	200VDC	50 μ A	5.8 Ω
C35	0.1 μ F / 200VDC	140VDC ³	500 μ A ³	4.2 Ω
C40	5 μ F / 1,000VDC ²	500VDC ⁴	0 μ A ⁴	1.2 Ω
C42	0.1 μ F / 200VDC	115VDC ³	500 μ A ³	4.2 Ω

¹ – Parts list calls for 0.1 μ F / 200VDC at this location, type listed was found installed

² – Parts list calls for 5 μ F / 1,000VDC at this location, replacement was 4.7 μ F / 1,000VDC

³ – This device could not be tested at full rated voltage due to excessive (maximum scale) leakage at lower applied voltage

⁴ – This device could not be tested at its full rated voltage due to test equipment limitations; however, no leakage at all was observed at the test rig maximum leakage voltage level.

As is evident from the data in *Table 1*, all of the capacitors believed to be originals had significant leakage and had considerably higher than acceptable ESR values. As such, it was best that these capacitors were all replaced. The aggregate leakage of these capacitors was a contributor to the excessive current drawn by the ‘scope on power-up.

The WO-33A Oscilloscope also uses two can-type multi-section aluminum electrolytic capacitors, each of which is a 450-volt 40 μ F/20 μ F/20 μ F/10 μ F four-section device. The replacement devices are of the same capacities, but are rated at 475 volts instead of the original 450 volts. These capacitors are used at locations C38A-D and C39A-D. C38 is in the 6BR8A pentode/triode vacuum tube vertical input amplifier circuit, while C39 is used as the incoming power filtering capacitors immediately subsequent to rectification by the 6X4 dual-diode vacuum tube. The original capacitors in these locations were unmarked as to manufacturer or date, but they were marked with a patent number and a part number (*Figure 8*). A quick Google search on the patent number showed that the patent was a 1952 (23 December 1952) application, made by Jerome J Kurland and Joseph J Kurland. Some more research showed that these two gentlemen were the co-owners of a company called Illinois Condenser Company of Chicago, Illinois. From that information, one would have to conclude that these capacitors were manufactured by the Illinois Condenser Company.

The replacement devices are the product of CE Manufacturing of Tempe, Arizona. CE Manufacturing produces a fairly extensive product range of multi-section can-type electrolytic filter capacitors, intended primarily as replacements for guitar amplifiers and older radio receivers. I have used their capacitors in several refurbishing projects over the past few years, always with great success. They are drop-in replacements as far as size, pinout, and appearance are all concerned.



Figure 8 : Original C38 Capacitor

On capacitors of this type, the individual sections are identified by a symbol (▲, ■, or ◐) adjacent to each terminal. In a four-section device, the fourth terminal is unmarked or marked with a line or dashes (--). In most cases, a legend is marked or labeled on the body of the capacitor (**Figure 9**), indicating which section carries which ratings, both as to capacity and as to voltage. The capacitor shell is the common negative side of the internal capacitors.

As with the discrete capacitors, I ran the leakage and ESR tests for these capacitors, with results shown in **Table 2** below.

Table 2

Device ID	Symbol	Value	Test Voltage	Leakage Current	ESR
C38A	--	10 μ F 450VDC	420VDC ¹	500 μ A ²	2.3 Ω
C38B	▲	20 μ F 450VDC	120VDC ¹	500 μ A ²	1.45 Ω
C38C	■	20 μ F 450VDC	190VDC ¹	500 μ A ²	1.35 Ω
C38D	◐	40 μ F 450VDC	110VDC ¹	500 μ A ²	1.0 Ω
C39A	--	10 μ F 450VDC	310VDC ¹	500 μ A ²	1.9 Ω
C39B	▲	20 μ F 450VDC	150VDC ¹	500 μ A ²	1.8 Ω
C39C	■	20 μ F 450VDC	265VDC ¹	500 μ A ²	1.3 Ω
C39D	◐	40 μ F 450VDC	175VDC ¹	500 μ A ²	0.7 Ω

¹ – This section could not be tested at its full rated voltage due to high leakage current

² – The leakage current shown is the full-scale value; actual leakage current is greater than the full-scale value and is beyond the measurement capability of the test meter used

As can be concluded from the values in the table above, the electrolytic capacitor sections all exhibited extremely high leakage. High leakage is quite typical of electrolytics, but generally not to the extent seen here. This leakage, taken together with the leakage of the film capacitors, was clearly enough to cause the excessive current draw seen in the initial power-up test.

It should be noted here that this oscilloscope, which carries serial number 1426, is not compliant with the schematic diagram provided in the assembly manual for this unit. According to the notes that apply to the schematic, units bearing serial numbers from 1001 through 2300 should have a pair of 0.01 μ F ceramic disc capacitors installed, one from each lead of the power cord to chassis ground at the power cord input to the oscilloscope. These capacitors, identified as capacitors C36 and C37, were not present.

The 'scope required replacement of its power cord because of the condition of the existing cord, as mentioned earlier. I replaced the cord with a two-prong polarized power cord, placing the LINE lead in series with the power switch, identified only as "POWER SWITCH" and ganged to the 75k Ω INTENSITY potentiometer R73. At that time, I also added the two 0.01 μ F capacitors from the power cord leads to the chassis. The capacitors I used are X1-440V/Y2-300V \pm 20% Y5V ceramic disc safety capacitors (**Figure 10**). Safety capacitors are specially designed so as to fail, when failure occurs, in the "open" state rather than failing "shorted". This is important in any capacitor placed across the power line or placed between the power line and chassis (or other) ground.



Figure 9 : Capacitor Label

The “X1-440V/Y2-300V” designation indicates that this capacitor can be used in the X1 circuit configuration at voltages up to 400VAC, and in the Y2 circuit configuration at voltages up to 300VAC. The X1 configuration is that in which the capacitor is placed across the power line, from one lead to the other, while the Y2 configuration is that in which the capacitor is placed in the circuit from one line cord lead or the other to the chassis or ground. In this oscilloscope, the capacitors C36 and C37 are used in the Y2 placement.

Continuing with the capacitor specifications shown for the safety capacitors, the “±20%” is the tolerance of the capacitor, or the variation from the nominal value within which the capacitor will fall. Thus, the 0.01 μ F capacitor will be found to be within the range of 0.008 μ F to 0.012 μ F. Finally, the “Y5V” is the designator for the dielectric used in construction of the capacitor. Disc capacitor dielectrics are assigned alphanumeric codes that describe the properties of that dielectric compound. Each of the three characters conveys a specific meaning. In this case, the “Y” indicates that the lowest temperature for which this capacitor is rated is -30°C (-22°F). The “5” indicates that the highest temperature for which this capacitor is rated is +85°C (+185°F). Finally, the “V” tells us that the amount of capacitance change over the temperature range is +22% to -82% of the nominal value. A table of the common dielectrics and their meanings can be found in the article Capacitor Markings and Identification, a part of my Basic Electronics Series, which can be found on my website at <https://www.ad2cs.com/electronics-articles-and-publications>. Please feel free to browse through the website and have a look at the many articles and publications found there.



Figure 10 : 0.01 μ F Safety Capacitor

Once all of the capacitors had been replaced and the new line cord and its associated safety capacitors were installed, I once again connected the ‘scope to the safety trinity and powered it up. This time, the bulb of the current limiter started out bright, and then rapidly faded to a more normal dim state. This was a good sign, showing that the current draw was at or near proper limits. I then took a reading of the actual current being drawn by the oscilloscope, and found it to be a very reasonable 438mA. Upon power-on, the initial current draw peaked at 1321mA, a not unexpected start-up surge. This data was important, because it enabled me to determine a proper fuse for installation as a protective device. In addition, it was right in line with the average power consumption of 50 watts that is stated in the assembly manual’s Electrical Specifications section, calculating out at about 51.465VA when the 438mA is multiplied by the measured 117.5VAC line voltage in my shop.

This oscilloscope, like many appliances of that era, did not have a fuse installed at the time of initial build. However, I am not of a mind to trust in the circuit designs of a bygone era for overload protection, so I decided to add a fuse to the ‘scope power inlet circuit. I mounted a standard 1/4” x 1-1/4” snap-in fuse holder (*Figure 11*) to the inside of the left side (from the rear) chassis panel, wiring the fuse in series with the power switch in the LINE lead of the power cord. As to the fuse value, I opted for a 1250mA (1.25A) slow-blow fuse. This provides adequate over-current protection while allowing for the momentary current surge at start-up.



Figure 11 : Keystone 3523 Fuse Holder

After installation of the fuse and testing of the fuse circuit, I performed a thorough cleaning of all of the front panel operational switches and potentiometers, using DeoxIT Gold (G100L 100% solution) as the cleaning agent, and using cotton swabs on the switch wafer contacts. The combination of the very slightly abrasive cotton swabs and the DeoxIT Gold served well to clean the switches. Care was taken to remove any cotton strands left behind during the cleaning process.

Next up was the replacement of the damaged BNC jack on the front panel. This was a simple process that actually completed the installation of capacitor C2, as one lead of this capacitor is connected to the center terminal of the BNC jack, via one side of a 4-40pF trimmer capacitor C1. When I placed C2 into position earlier, I simply left the BNC jack end of the capacitor disconnected, pending the replacement of the BNC jack. The body of the BNC jack is directly mounted to the chassis, with no wire interconnect involved at that location.

With the repairs and cleaning completed, it was time to pay some attention to the external appearance of the unit. This turned out to be a relatively minor issue, as the blue paint which had been splattered across the front panel, the upper surface, and the left side panel all came off with some acetone on a soft cloth. The remainder of the stains and debris on the enclosure all came off with some denatured alcohol and another soft cloth, using an old toothbrush to scrub the corners and crevices. A final wipe-down of the front panel with the denatured alcohol finished the clean-up of the unit, though I still need to find a way to safely remove some tape residue without damaging the RCA logo, as can be seen in the *Figure 12* photo.



Figure 12 : Working Oscilloscope

At this point, the **RCA WO-33A Oscilloscope** is operating in accordance with its design standards (*Figure 12*), and is ready for its final conversion to its new purpose and life as a semiconductor device curve tracer. The next step is to design and construct both the power supply and the curve tracer interface board. Once they have been designed and bread-boarded, I will have the PCB's manufactured. After that, I can install them into the oscilloscope enclosure, mounting them to the chassis rails. I will write another article describing those processes as they progress to completion.

For now, I will say farewell!